

Informations techniques/Technical Matters

DATE October 27th, 1971.SUBJECT: 1972 GRAND PRIX- SLIDER SUSPENSION.RE: RETAINING BOLTS OF THE FRONT AND REAR TENSIONER ARMS.

Take note that the tensioner arms (ref. 2, fig. 1) of the slides (ref. 1) should be allowed to move freely.

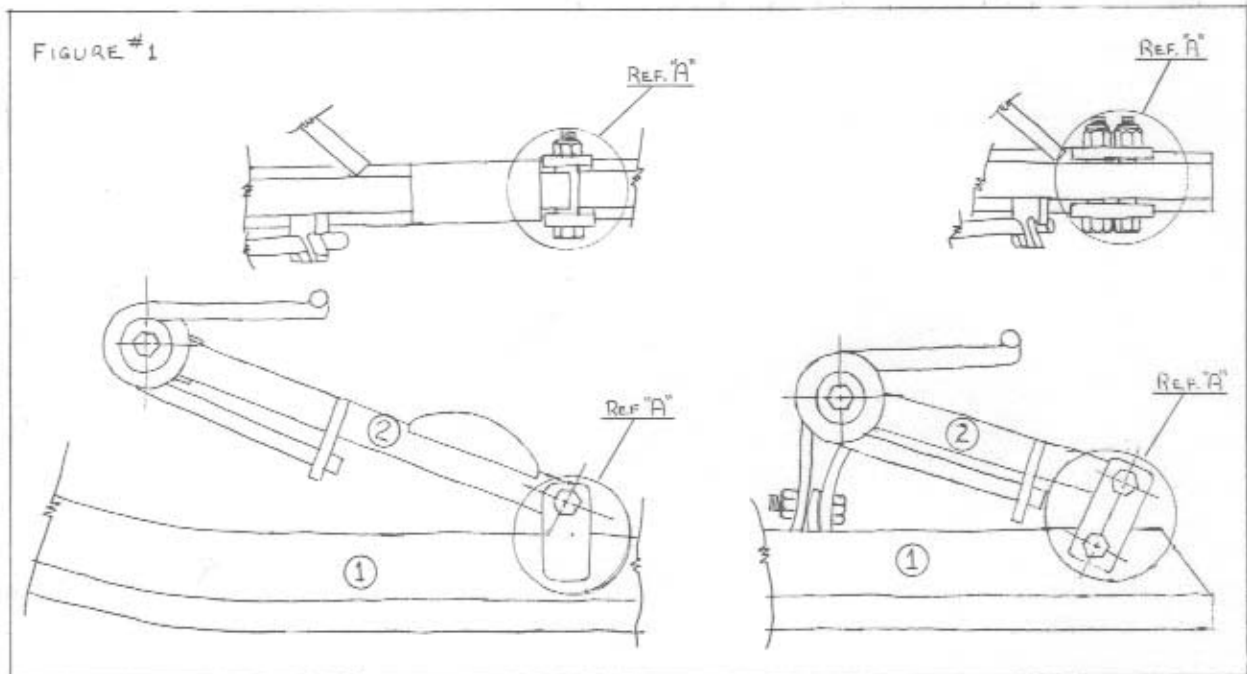

Therefore, these bolts (ref. A, fig. 1) should never be fully tightened. When assembling or repairing a slider suspension, make sure that these bolts are not restricting the movement of the tensioner arms.

RL/lb

Technical Information Department.